



Connection Diagrams for Motorized Pulleys 138E - 400L

Cable Connection

Cable wires with numbers

T1 & T2 = Thermal Protector
 EB = Electromagnetic brake
 B1 & B2 = EB

01

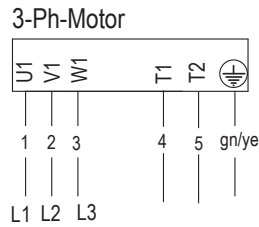

02

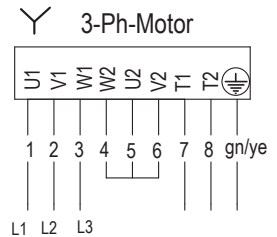
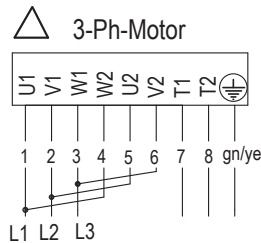

03

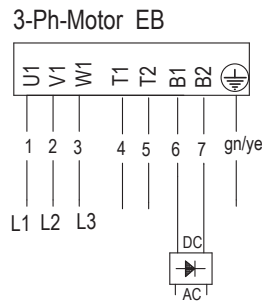

04

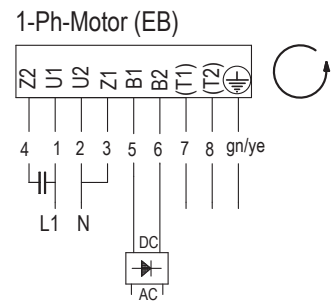
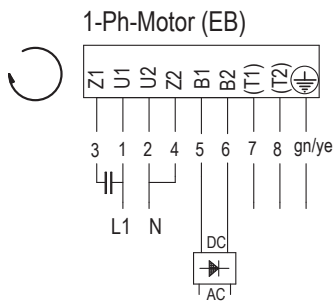

Connection Diagrams for Motorized Pulley with Compact Terminal Box and WAGO-Clamp 138E - 400L & power ≤ 4.0 kW

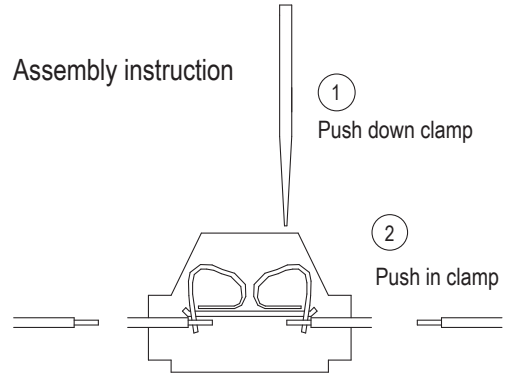

Characters in brackets for 2 stage gearbox!

EB = Electromagnetic brake

Clamps B1 and B2 are for standard unassigned

- RD = Red
- YE = Yellow
- BK = Black
- GY = Grey
- BU = Blue
- GN = Green
- WH = White
- BN = Brown
- T1 & T2 = Thermal Protector
- B1 & B2 = Electromagnetic Brake

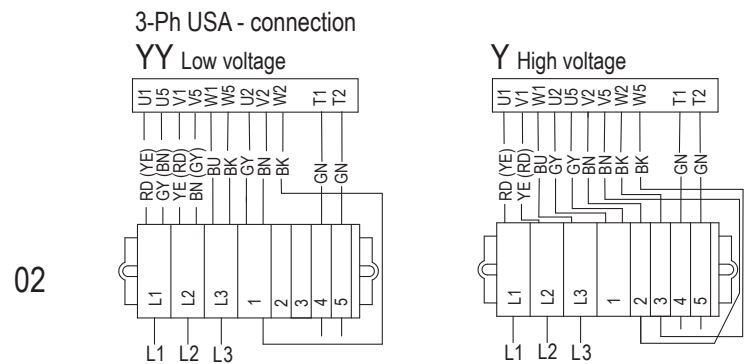
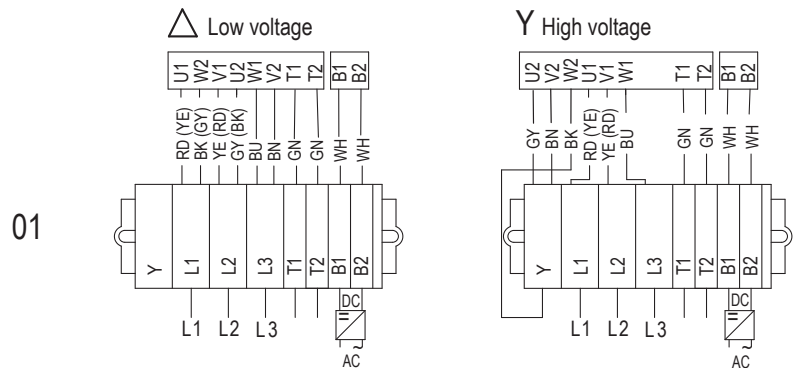

Note: check the star (U2/V2/W2) before reconnection!

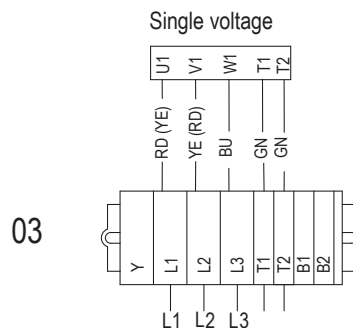

External Connection Diagrams for Motorized Pulleys 5.5 kW 250 kW

Low voltage - Δ

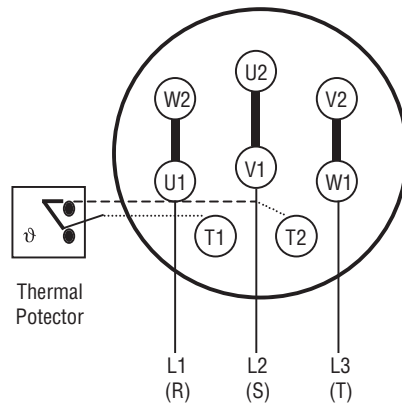

High voltage - Y

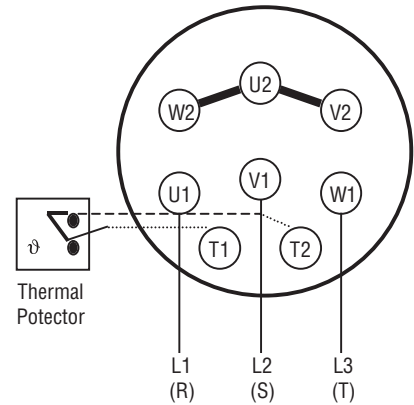

Terminal Box 5.5 kW - 132 kW

Electromagnetic Brake Execution

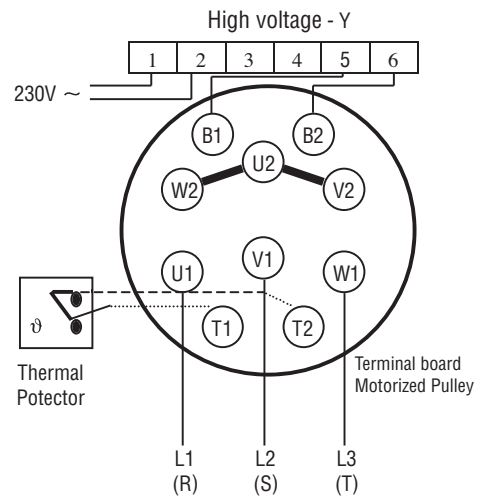
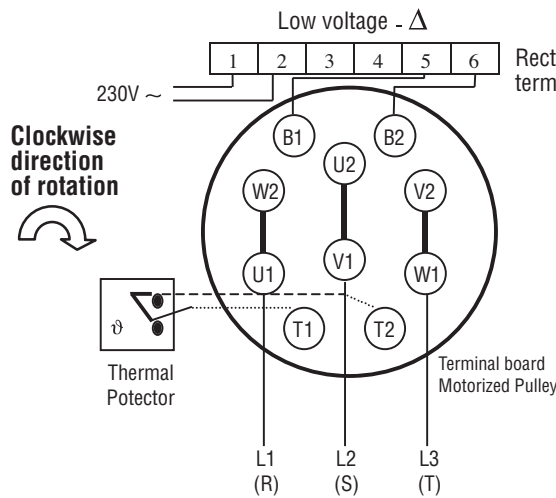

3-phase single voltage 5.5kW - 250kW

USA - Execution

Low voltage - YY

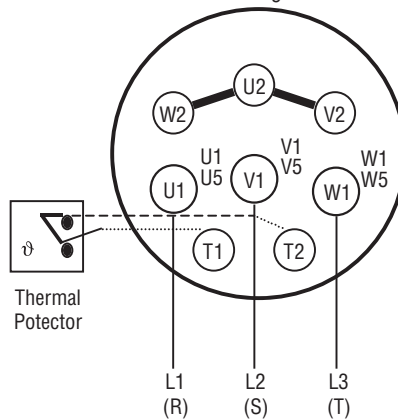
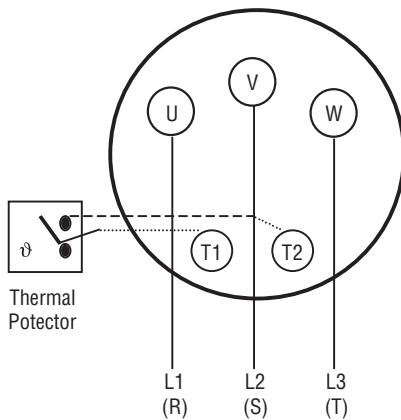

High voltage - Y

